



VOLVO V60
& V60 CROSS COUNTRY



INNOVATION FOR PEOPLE

Made by Sweden.

At Volvo Cars, we continuously innovate in order to make your life better. Every car, every technology and every design is the result of a clear vision – to put people at the heart of everything we do. It's a vision that has driven us from the start, one informed by Sweden, a country which values people as individuals and where conventions are challenged. It's a culture with a rich design heritage and a unique way of looking at the world.

This vision has inspired us to create the likes of the three-point safety belt and side-impact airbags – inventions that have saved lives and changed automotive history. And with our new generation of models we continue with this tradition.

Scandinavian design combines with modern Swedish luxury to enrich your experience. Intuitive technology makes life less complicated and keeps you connected with the world, while the latest Drive-E powertrains balance responsive power with class-leading efficiency. And our IntelliSafe innovations support you while you are driving, helping to prevent accidents and protecting you if one occurs. They make every journey safer, more comfortable and enjoyable.

We understand what's important to people. It forms the basis of all the innovations which we create. Innovations that improve lives.

At Volvo Cars we design our cars around you.

Contents

EXTERIOR DESIGN | 04

INTELLISAFE | 14

CHASSIS | 26

ACCESSORIES | 76

INTERIOR DESIGN | 08

DRIVE-E | 18

YOUR CHOICE | 28

FACTS AND FIGURES | 84

SENSUS | 10

VOLVO V60
TWIN ENGINE | 22

TRIM LEVELS | 30

THE VOLVO EXPERIENCE | 88





The V60 is designed to help you make the most of your life, whatever you are doing. It's a car that makes you feel special through the enjoyment, comfort and beauty it provides; a car for people who need the versatility of an estate as well as an entertaining driving experience.

It starts with the standard Dynamic Chassis, which we spent thousands of hours tuning in order to create a responsive, in-command feeling behind the wheel.

A range of Drive-E powertrains give you responsive performance as well as low fuel consumption and emissions. By using lightweight construction, low-friction technology and advanced transmissions they get the most out of every drop of fuel.

Inside, the V60 blends Volvo practicality with an atmosphere of calm and serenity. Our seats have been famous for their comfort ever since we took the unprecedented step of consulting ergonomic experts to help us develop them, and the current generation is the latest example of this revolutionary approach. Supportive and comfortable, you will arrive fresh and relaxed after even the longest journey.

Sensus – our way of connecting you with your Volvo and the world around you – puts the latest technology at your command, in a way that's intuitive and natural. For the V60 it includes high-quality displays and easy-to-use controls that make life easier, as well as the option of high-end audio systems and internet connectivity that keeps you in touch with your digital world on the move.

Inside and out, the V60 embodies the best in Scandinavian design. You see it in the elegant and uncluttered interior, with its alluring blend of modern materials and traditional craftsmanship; in the calm, confident presence the V60 has on the road. Elegant, versatile and distinctly different, the V60 is a car designed around the way you live. A car that has the power to make you feel good every day.





"It's your sportswagon, worthy of the name."

VOLVO V60

*Why give up the thrill
of driving just because you
need to carry stuff?*

The Volvo V60 is a beautifully balanced combination of dynamism, style and versatility.

When driving on winding roads you'll enjoy the crisp response of a well-balanced chassis. During longer trips, the relaxed comfort of your V60 will keep you and your passengers feeling fresh for hours. In more challenging traffic situations – in the city, for example – a range of supportive technologies will take the stress out of driving and keep you in control.

The agile character of your V60 is enhanced by its looks. The muscular shoulders,

the distinctive front with advanced headlamps, the sleek coupé-like roof line and the powerfully sculpted rear section with its signature rear light arrangement – all make for a strong road presence. Inside, a beautifully crafted interior creates a calm yet invigorating environment that creates a unique sense of well-being, exactly as befits a Scandinavian design masterpiece.

To support the more practical aspects of life, smart versatility including a 430 litres load compartment and a 40/20/40 three-

split backrest will come handy. You conveniently bring both people and gear without compromising on either comfort or safety. Add our range of highly efficient Drive-E powertrains including our Twin Engine plug-in hybrids and our Sensus technology that connects your Volvo with the world around you – the V60 is truly designed to fit in with your life, whatever it involves. It's your sportswagon, worthy of the name.





“The car has a beauty that – as with much of contemporary Scandinavian design – is rooted in the natural world.”

HOW DO YOU MAKE A BEAUTIFUL ESTATE?

By design.

The looks tell you this car is a beautiful combination of versatility and performance. “The road presence comes from its focused and determined-looking headlights,” explains our senior exterior designer Peter Reuterberg. “We were thinking of a wolf’s eyes when we designed the car’s “face”. It has a confident, focused expression, like a powerful animal.” Our designers have also made the roof sweep down and the rear windows taper – the overall

effect is to make it appear more like a coupe. Meanwhile, the scalloped surfaces on the bonnet accentuate the classic Volvo V-shape with a purposeful frown running right down to the headlights. The car has a beauty that – as with much of contemporary Scandinavian design – is rooted in the natural world. “Those clean surfaces and contours give it a very Scandinavian feel,” says Peter Reuterberg. “The way surfaces build up and then change

shape is inspired by snowdrifts in the Swedish countryside – it’s a combination of soft forms and sharp breaks.” The strong shoulders are another unmistakable Volvo design cue – as is the expressive grille with the iconic Volvo diagonal. They enhance the car’s self-confident look and tell the world it’s proud to be a Volvo.



“We’ve designed the cockpit around you, the driver.”



We’ve designed the cockpit around you, the driver. Sit in the driver’s seat and the dashboard, which is gently angled towards you, puts you in complete command. Inspired by high-performance motorcycles, we came up with the idea of a single round instrument flanked by two smaller dials. Then, we carefully sculpted the three-spoke steering wheel with the aim of giving you a clear sense of connection between your car and the road.

Where you sit is equally important. Volvo takes pride in designing seats that not only offer great comfort but also outstanding support, so that at the end of every journey you make you will feel as calm and refreshed as when you started. Our sport seats look great and, true to our commitment to ergonomic design, side supports all the way from your thighs to your shoulders ensure that you stay firmly in position, even when you’re cornering fast.

And because it’s a Volvo, we designed the seats so your passengers will enjoy the ride too. Everybody travels first class, and with our two-stage integrated booster cushions children over 3–4 years will ride safely in comfort while seated in the right position.

Of course, we’re committed to a clean environment inside your car as well. As part of CleanZone, all interior materials in your Volvo are hypo-allergenic and do not emit harmful gases. CleanZone also includes a highly effective dust and pollen filter. You can boost this further with our Interior Air Quality System. This uses an active carbon filter to reduce harmful gases and particles, enabling you and your passengers to breathe easily – even in polluted cities.

No need to take your hands off your steering wheel as you shift up and down the automatic gearbox in manual mode – just flick through the gears with our optional gearshift paddles. You’ll be in total command of your car, with both hands on the wheel. And quicker gear changes for a more responsive drive when you’re in the mood.



“Sensus is about making your interaction with your car intuitive, and ensuring you’re on the road, but not offline.”

SENSUS

The intuitive way to interact with your car.

Volvo Sensus is our all-encompassing approach that connects you with your car and the world around you. It means you’re on the road, but not offline. With Sensus Connect, you can turn the 7-inch screen in your dashboard into an internet-connected infotainment hub. Not only can you surf the web, you can also download apps – from Stitcher to TuneIn. Sensus Connect also gives you access to basic internet maps and routing, and to take advantage of navigation guidance, 3-D views and navigation apps, there’s our Sensus Navigation option. If you’d like to take your connectivity to the next level, there’s Volvo On Call. This option gives you 3G-connectivity with excellent reception through your car’s integrated roof

aerial, so you can create a wifi hotspot for all of your devices. Meanwhile, Connected Service Booking allows you to book your car in for a service from the comfort of the driver’s seat.

A high-end audio experience is also part of Sensus. That’s why we’ve designed our state-of-the-art Premium Sound with Harman Kardon®. Using 12 high-fidelity loudspeakers, the amplifier is equipped with Dirac Live®, the next generation sound enhancement software. With an incredibly realistic stage sound as well as enhanced bass performance, this sound system provides an unparalleled aural experience for every passenger and connects easily with external media players.

Our digital driver display is another delight. Not only does it give you all the information you need without overwhelming you – its three background modes, Elegance, Eco, and Performance, also sync with the centre screen. The physical controls, such as our floating centre stack with its iconic ‘manikin’ climate control buttons, are another example of Swedish design that’s both functional and beautiful. And then there’s our eye-catching illuminated gearshifter, which is available for selected automatic gearboxes. Glowing gently in the dark, it adds a touch of atmosphere to your night drives.



A special connection. Volvo On Call allows you to connect with your car as never before, while also connecting your car to the outside world.

At its heart is a smartphone app you can use to check on – and interact with – your car no matter where you are. This is very handy if, for example, you want to pre-heat your car in time for your arrival. And to go online, the package includes a built-in modem and dedicated SIM-card slot. Volvo On Call also provides help when you need it most. The On Call button in the passenger compartment puts you through to breakdown services. And in emergencies, the passenger compartment's SOS button provides an instant link to a team of Volvo On Call professional operators. To cover any eventuality, if there are indications that you've had an accident (such as a deployed airbag), we will call you. If there's no response, we'll send the emergency services to you straight away.

READ MORE AT VOLVOCARS.COM

SENSUS



“Our vision is that by 2020 nobody should be killed or seriously injured in a new Volvo.”

INTELLISAFE

*Intuitive safety by Volvo Cars.
For you, and for those around you.*

At Volvo Cars, safety is an intrinsic part of our DNA. We've invented some of the world's most pioneering life-saving technologies – such as the three-point safety belt that's been acknowledged as one of the most important innovations of mankind.

But we aim higher. Our vision is that by 2020 nobody should be killed or seriously injured in a new Volvo.

IntelliSafe is our approach for a more harmonious relationship between cars and people. To achieve this, we have infused your Volvo with smart, intuitive innovations for a safer drive. And the IntelliSafe technologies will not only help protect the people inside your car – we also consider people on the outside, for example with technology that helps you to detect pedestrians and cyclists.

When you drive at speeds up to 50 km/h, our City Safety collision avoidance technology looks ahead of you and brakes automatically if you're about to run into a vehicle in front.

To give you more support at higher speeds, our Collision Warning with Auto Brake and Pedestrian and Cyclist Detection alerts you if you're too close to a vehicle and a collision is imminent – day or night. During daylight, the system also reacts if there's a pedestrian in your path or a cyclist ahead travelling in the same direction as your car. And if necessary, your car brakes automatically to help you avoid or mitigate a collision.

To help you stay in the lane, our Lane Departure Warning or Lane Keeping Aid technology will alert or intervene should you unintentionally cross a lane marking – there's even Driver Alert technology that reminds you to take a break if your driving behaviour shows signs of drowsiness.

Our IntelliSafe technologies also support your daily driving. The Road Sign Information technology keeps you updated on actual speed limits and other important road signs. At night, our Active High Beam stays on high

beam all the time to optimise your vision without dazzling other road users. And to make you a bit more relaxed on the road, our Adaptive Cruise Control can maintain your set speed and distance to the vehicle in front. In slow-moving city traffic, our Queue Assist function can automatically maintain the selected distance to the car in front – from standstill and up to 30 km/h. Our BLIS™ system helps you to early detect other vehicles in your blind spot, while the Cross Traffic Alert function facilitates reversing out of tight parking spaces where your vision can be restricted.

And because we know you love to drive, our active IntelliSafe technologies such as Electronic Stability Control add to reassuring driving stability in all conditions without sacrificing the joy of driving. It's simply about giving you the most human-centric driving experience, on your terms. And helping to keep people out of harm's way, whether they happen to be inside or outside your car.



Light up the dark. Driving in the dark just became a lot more enjoyable and safer. Our Active High Beam stays on high beam all the time. You don't have to flick between low and high beam, and when you meet or catch up another vehicle the system shades out only as much of your beam as necessary to avoid dazzling – while you still get the benefit of a brightly lit road. This intelligent technology can even recognise pedestrians and cyclists and avoid dazzling them too. And when you enter a city, the high beam switches off.

FIND OUT MORE AT VOLVOCARS.COM



City Safety is designed to prevent you from colliding with the car in front if it stops or slows down suddenly. This advanced IntelliSafe system will automatically brake to avoid a collision and works at speeds of up to 50 km/h – an accident can be avoided at a speed difference of up to 15 km/h to the vehicle in front.

Because we also care about other road users, our pedestrian and cyclist detection with full auto brake watches out for people walking in your path or cycling in the same direction as your car and applies the brakes if you're unable to react in time.

Our BLIS™ system uses radar sensor technology to alert you to vehicles that are close to, or within, your blind spots in your adjacent lane. This way, you're far less likely to change lanes when it isn't safe.

When you're reversing out of tight parking spaces, our Cross Traffic Alert function watches out for vehicles you can't see.

READ MORE AT VOLVOCARS.COM



INTELLISAFE





“With our new generation 2.0-litre, four-cylinder Drive-E powertrains you don't need to sacrifice power and superb driveability for efficiency and low CO₂ emissions.”

DRIVE-E

*Enjoying more.
Using less.*

Drive-E isn't just about our new generation of efficient powertrains, it's about our all-embracing approach to efficient driving. And while we're committed to creating smarter, more innovative technologies to reduce our cars' impact on the environment, we'll never lose sight of the pleasure to be had in driving. In short, we believe you don't need to sacrifice power and superb driveability for efficiency and low CO₂ emissions.

Our Drive-E powertrain range consists of highly efficient 2.0-litre, four cylinder petrol and diesel engines. We've matched

these turbocharged, low-friction, lightweight powertrains with Geartronic™, our all-new eight-speed automatic gearbox, which ensures you get optimum performance at any engine speed.

Your Volvo also has an ECO+ function which can reduce fuel consumption by up to five per cent, depending on driving style. ECO+ not only optimises shift points, engine control and throttle response. It also includes a Stop/Start system and an ECO coast function. This disengages the clutch when you release the accelerator at speeds above

65km/h: instead of the engine braking the car and using up fuel in the process, your Volvo will coast along using its kinetic energy.

Our Drive-E diesel powertrains have additional technologies designed to reduce fuel consumption and emissions. Twin turbochargers and the revolutionary i-ART ensure that these intelligent engines provide responsive, clean and efficient performance – each cylinder has its own microchip and pressure sensor for perfect metering of fuel. Better still, these advanced engines remain in precise tune even after years of use.

The Volvo V60 is available with a wide range of cutting-edge petrol and diesel engines designed to meet your preferences. All of them are designed to offer maximum driving pleasure while using fuel efficiently and keeping CO₂ emissions at a minimum.

Are you looking for maximum power? Our highly efficient T6 petrol engine with supercharger/turbo technology puts out 306hp at 157g CO₂ emissions for an exhilarating driving experience. Alternatively, our high-performance 225hp D5 and 190hp D4 diesel powertrains will provide uncompromised efficiency and refinement while just emitting 125g respectively 101g CO₂/km. Or do you want the ultimate combination of fuel economy and performance? Then choose our 120hp D2 engine, which consumes just 3.7l/100km and emits 98g CO₂/km. With the 152hp T3 petrol powertrain you'll benefit from a fuel consumption of a mere 5.8l/100km (135g CO₂/km). And if you want the best of both worlds, our D5 Twin Engine AWD and D6 Twin Engine AWD with plug-in hybrid technology have a combined output of 231hp or 288hp, respectively, while emitting between 48g and 0g CO₂/km.

Fuel consumption and CO₂-emissions figures apply to cars with automatic transmission except for the D4 and D2 which are available with a manual gearbox.

READ MORE AT VOLVOCARS.COM



DRIVE-E



Smart power
for clever people.



We don't think that being environmentally aware should mean you lose the thrill of driving. Our plug-in hybrid V60 D6 Twin Engine AWD or D5 Twin Engine AWD does 0–100 km/h in under seven seconds yet emits just 48g/km of CO₂*. It's got three driving modes: Pure uses just its electric

motor, emitting zero CO₂; Hybrid uses the diesel engine and electric motor and should give you fuel consumption of 1.8l/100km; Power gives you both diesel engine and electric motor at full capacity – giving you a very impressive power and torque as well as instant four-wheel-drive (the diesel engine

drives the front wheels, while the electric motor drives the rear). And if you'd like to complement the performance of the V60 Twin Engine with an even sportier look, there's an R-Design version, too.

*NEDC Hybrid driving cycles.





Connect the V60 Twin Engine to your home's electricity supply and, depending on your power supply, you'll get a full charge in 3.5 to 7.5 hours. While driving, you can choose from three modes (PURE, HYBRID and POWER) to suit your location and your mood.









It's not your usual wagon.

We've worked hard to combine the versatility and load-carrying capability of the V60 with natural driving dynamics so that – like its sister, the S60 saloon – it responds faithfully to your desires.

When you accelerate out of a tight corner, for example, your V60 will follow the path you choose with almost telepathic accuracy. A good chassis is the essential foundation for this, and you can choose from four types according to your preferred driving style: Touring, Dynamic, Four-C and R-Design Sport chassis.

Meanwhile, at the heart of versatility is the intelligent seating. The backrest can be easily folded down in 40/20/40 segments to supplement the rear 430 litres of load space, while the front seat backrest can be folded down, too. And parents will love the two-stage integrated booster cushions for children: they fold out of the rear seats, ensuring that kids who've outgrown their child seats are at the correct height for their seat belts to work effectively.



FREEDOM OF CHOICE, YOUR CHOICE

In a Volvo, you can enjoy the finer aspects of freedom. Such as the freedom to explore new roads, the freedom to enjoy the experience and – not least – the freedom to create a car that matches your style and personality. Choosing a Volvo is more than a statement of your personality. It's about knowing what's most important in life and going in that direction. To show a greater care for people and the world we share, and never compromise with design and quality. To choose a car that's more human-centric, more intuitive and more efficient – simply much of what empowers you to live a rich, authentic life.

To ensure you get your new Volvo V60 or V60 Cross Country exactly as you want it, we have created a wide range of options, trim levels and personal expressions. Even if your V60 or V60 Cross Country is already generously equipped as standard and in the Kinetic trim level, you may want to enhance the experience even further with the Momentum trim level. Maybe you want to indulge your senses in the finest Scandinavian luxury. Then you'll feel at home with Summum. Or if you're in for an even sportier style inside and out: why not take a look at R-Design or – for truly impressive performance – the V60 R Polestar? Whatever you

prefer, you can rest assured there's a Volvo V60 or V60 Cross Country for you. Read on, and see what your new V60 will look like. And if you already know it is the V60 Cross Country that best befits your adventurous lifestyle, you can go directly to page 52.



Volvo V60 Kinetic



Volvo V60 Momentum



Volvo V60 Summum



Volvo V60 R-Design



Volvo V60 Cross Country



Volvo V60 Polestar

NB. The trim levels may vary from country to country. Please talk to your Volvo Car dealer for the latest information.

THE RIGHT EQUIPMENT FOR YOUR DRIVE

Choosing a Volvo V60 is the easy part. And now all you need to do is select the equipment level that's right for you. The Kinetic equipment level will already provide you with a high level of technology that will meet high demands on style, comfort and safety. For example, you get our world-leading IntelliSafe technologies including the award-winning City Safety collision avoidance technology and advanced Electronic Stability Control as standard.

To further enhance your Scandinavian luxury experience, there's the option of our Momentum equipment level. Bright deco exterior design elements together with larger 17-inch wheels will add to the exclusiveness and road presence of your V60, while the sporty elegant Textile/T-Tec upholstery and Milled aluminium decor inlays complement the interior ambience. With Momentum, you can also enjoy the clear sound reproduction of our High Performance audio system

including Bluetooth® music streaming and convenience enhancing features such as rear park assist. And when driving in the dark, the Active Bending Lights with Dual Xenon illumination technology allow you to enjoy the benefit of boosted vision round bends at night. Adding our Active High Beam functionality, you can stay on high beam all the time without dazzling other road users.

V60

Includes:

16" steel wheels | 3-point safety belts on all 5 seats with belt reminder | 40/20/40 split rear seat | Airbag, driver & passenger side | AUX input | Charcoal decor inlays | City Safety | Corner Traction Control (CTC) | Dual cup holders, front | Electronic Stability Control (ESC) | Electrically operated parking brake | Electronic Climate Control (ECC) with ventilation outlets in B-pillars | Front seat 12V outlet | Headlamp level adjuster | Illuminated vanity mirror, passenger side | Inflatable Curtains (IC) | ISOFIX, rear | LED DRL (Daytime Running Light) | Load cover | Mellbystrand textile upholstery | Outer temperature gauge | Remote control central locking | Sensus infotainment with 5" colour screen in the centre stack and Performance audio system with CD player | Side impact airbags integrated in the front seats | Trip computer | Tyre sealant kit | Tyre Pressure Monitoring System (TPMS) | WHIPS™ (whiplash protection integrated in the front seats)

KINETIC

Includes Base equipment level plus the following:

16" Hera alloy wheels | Audio controls in steering wheel | Cruise control | Illuminated vanity mirror, driver side | Leather-clad gear knob | Leather-clad steering wheel | Textile floor mats | Lock door switch passenger side

MOMENTUM

Includes Kinetic equipment level plus the following:

17" Pallene alloy wheels | Automatically dimmed frameless inner mirror | Bluetooth® | Bright work around side windows | Tylösand Textile/T-Tec upholstery | High Performance audio system | Leather-clad steering wheel with silk metal inlay | Metal luggage threshold | Park assist rear | Rain sensor | Retractable rear-view mirrors with ground lights | Milled Aluminium decor inlays | Uni decor climate control manikin

1-2. V60 Kinetic with 16-inch wheels. **3.** The V60 Kinetic features a leather-clad steering wheel and analogue driver display. **4.** Inside the V60 Momentum, you'll find a leather-clad steering wheel with Silk Metal inlay, an analogue driver display and our excellent High Performance audio system with convenient steering wheel controls and Bluetooth® audio streaming. **5.** Park Assist gives helpful support when reversing your V60 Momentum. **6.** V60 Momentum with 17-inch wheels and bright deco exterior details for an elegant appearance.

1



2



3



4



5



6



Providing a wide range of exterior colours and wheels, the Volvo V60 allows you to create a sportswagon that's really you. Going for Kinetic, you get 16-inch alloy wheels, while Momentum gives you the option of larger 17-inch wheels. The exterior colour you choose has a dramatic impact on the personality of your V60. Available in different variations, each colour imbues your Volvo with a sense of sporty luxury and presence.



Bor, 8x19"
Tech Black/Diamond Cut



Portia, 8x19"
Silver Bright



Portia, 8x19"
Black/Diamond Cut



Skadi, 8x18"
Silver Bright



Titania, 8x18"
Black/Diamond Cut



Ymir, 8x18"
Black/Diamond Cut



Tucan, 8x18"
Silver Bright



Sadia, 8x17"
Silver



Pallene, 7x17"
Silver



Rex, 7x17"
Silver



Hera, 7x16"
Silver



614
Ice White



707
Crystal White pearl



711
Bright Silver metallic



477
Electric Silver metallic



721
Mussel Blue metallic



713
Power Blue metallic



467
Magic Blue metallic



714
Osmium Grey metallic



492
Savile Grey metallic



717
Onyx Black metallic



019
Black Stone



719
Luminous Sand metallic



702
Flamenco Red metallic



612
Passion Red

The interior of the V60 is created with you as the centre of attention. Every detail, every line, every shape is testimony to our designers' pursuit to create a space in which you feel relaxed and in complete control. The Kinetic trim level features ergonomic seats upholstered in Charcoal Textile. For a more elegant yet sporty look and feel, the Momentum trim level includes Textile/T-Tec upholstery. The interior ambience is further enhanced by decor inlays in Milled or Brushed Aluminium.



UPHOLSTERIES Mellbystrand, Textile **1.** Charcoal in Anthracite Black interior with Quartz headlining, K001 (Base, Kinetic) **Tylösand, Textile/vinyl** **2.** Charcoal/Offblack in Anthracite Black interior with Quartz headlining, K601 (Momentum) **3.** Charcoal/Offblack in Anthracite Black interior with Charcoal headlining, K661 (Momentum)

INLAYS **4.** Charcoal (Base, Kinetic) **5.** Milled Aluminium (Momentum) **6.** Brushed Aluminium (Momentum)

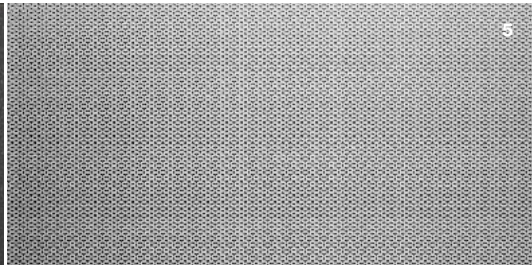
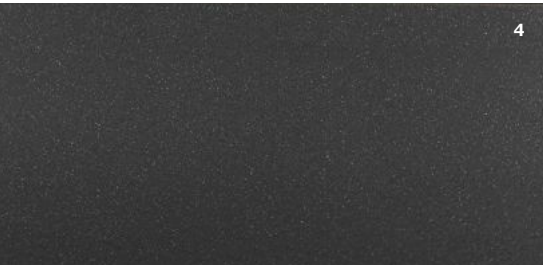
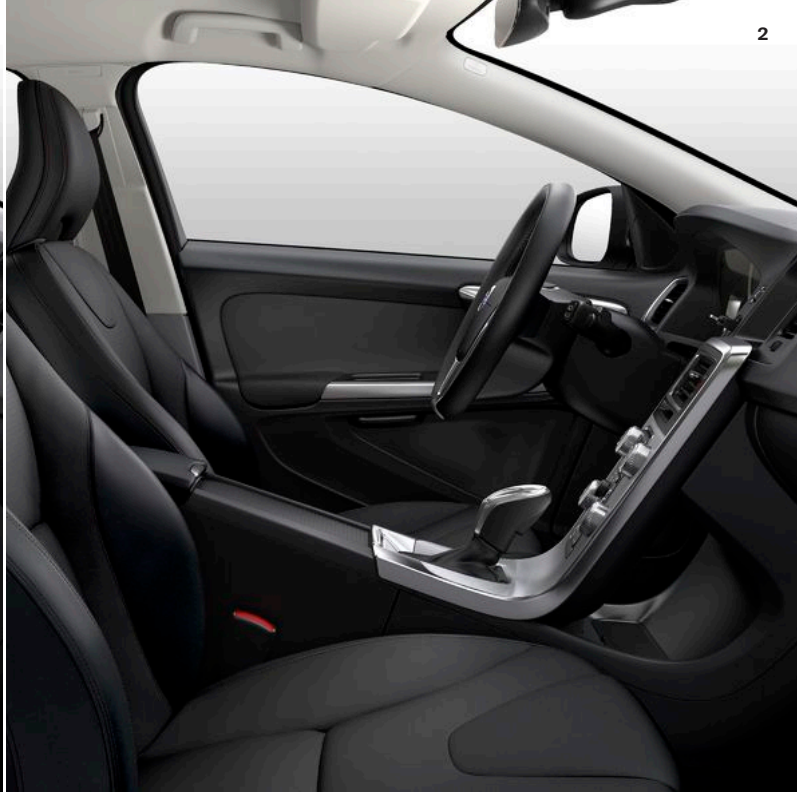



A HIGHER GRADE OF LUXURY

We created the V60 Summum to meet your highest expectations of Scandinavian luxury. It's a personal expression that evokes a strong sense of elegant refinement. Each detail is there to give you and your passengers a sophisticated and invigorating

experience. Distinguished exterior design cues enhance the luxurious look and feel of the V60, while the meticulously crafted interior gives you ample room for a relaxed driving experience. The V60 Summum epitomises our proud heritage of human-centric

design. And when it comes to intelligent luxury imbued with distinctive style and fresh thinking, the V60 Summum is in a class of its own – just like you.

SUMMUM

Includes Momentum equipment level plus the following:

17" Rex alloy wheels | Digital driver display | Leather upholstery | Power driver seat with memory function for seat and side mirrors | Rear armrest with cup holders and storage | Roof rails, bright | Chrome front

Summum is Volvo V60 in its most luxurious guise. Well-judged exterior design cues such as front chrome inlays and bright roof rails combine with the stylish 17-inch alloy wheels to enhance the car's timeless Scandinavian design. The wheels also contribute to the car's confident stance.

Inside, the luxurious theme continues with authentic, finely crafted materials that create a lounge-like atmosphere of

sumptuous well-being. As a driver, you can lean back in a sculpted power-operated Comfort or Sport seat with smooth leather upholstery and enjoy the intuitive view of the digital driver display. Depending on your mood, this display gives you three graphic modes to choose from: the default mode Elegance with its stylish black colour theme, the green Eco mode and Performance mode in striking red. The memory function of the

power seat allows you to store your settings both for the seat and the door mirrors. Every time you use your remote control to unlock the car, the driver's seat and the door mirrors will automatically adjust to your last settings. And for your passengers in the leather rear seat, an armrest with cup holders and storage adds to relaxed comfort and convenience.

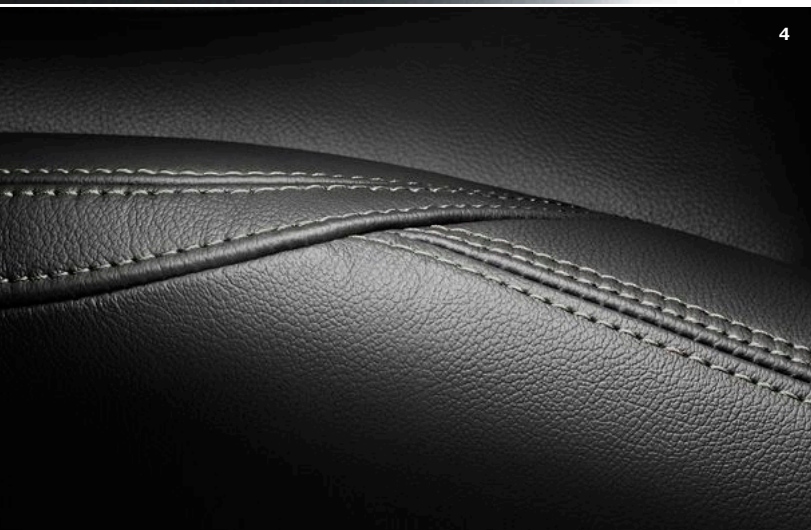

The V60 Summum exterior with its subtle design touches is a timeless expression of classical Scandinavian design. The exterior colour palette allows you to create the V60 Summum that best reflects your style and preferences. Available in a wide range of design expressions, the alloy wheels connect visually with the exterior design cues to create a harmonic impression of contemporary elegance.



Bor, 8x19"
Tech Black/Diamond Cut



Portia, 8x19"
Silver Bright



Portia, 8x19"
Black/Diamond Cut



Skadi, 8x18"
Silver Bright



Titania, 8x18"
Black/Diamond Cut



Ymir, 8x18"
Black/Diamond Cut



Tucan, 8x18"
Silver Bright



Sadia, 8x17"
Silver



Pallene, 7x17"
Silver



Rex, 7x17"
Silver



614
Ice White



707
Crystal White pearl



711
Bright Silver metallic



477
Electric Silver metallic



721
Mussel Blue metallic



713
Power Blue metallic



467
Magic Blue metallic



714
Osmium Grey metallic



492
Savile Grey metallic



717
Onyx Black metallic



019
Black Stone



719
Luminous Sand metallic



702
Flamenco Red metallic



612
Passion Red

Inside the V60 Summum, you are surrounded by thoughtful luxury. There are genuine materials and fine craftsmanship wherever you look – a sensory experience further enhanced by the ergonomically designed Comfort or Sport seats in smooth leather. And to make it easy to give the interior your own signature, you have an extensive range of interior colours, upholsterys and decor inlay combinations to choose from.



Comfort seat



Sport seat

UPHOLSTERIES Leather Comfort 1. Offblack in Anthracite Black interior with Quartz headlining, K701 2. Offblack in Anthracite Black interior with Charcoal headlining, K761 3. Soft Beige in Anthracite Black interior with Soft Beige headlining, K70P 4. Soft Beige in Sandstone Beige interior with Soft Beige headlining, K71T **Leather Sport** 5. Offblack in Anthracite Black interior with Quartz headlining, K301 6. Offblack in Anthracite Black interior with Charcoal headlining, K361 7. Soft Beige in Anthracite Black interior with Soft Beige headlining, K30P 8. Soft Beige in Anthracite Black interior with Charcoal headlining, K36P 9. Beechwood Brown/Offblack in Anthracite Black interior with Quartz headlining, K303 10. Beechwood Brown/Offblack in Anthracite Black interior with Charcoal headlining, K363 11. Soft Beige in Sandstone Beige interior with Soft Beige headlining, K31T

INLAYS 12. Milled Aluminium 13. Brushed Aluminium 14. Urbane Wood 15. Piano Black Wood

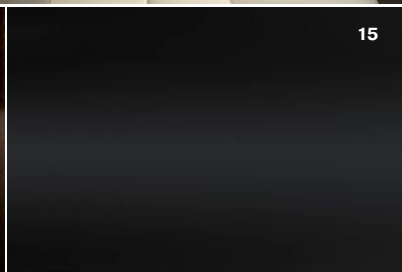
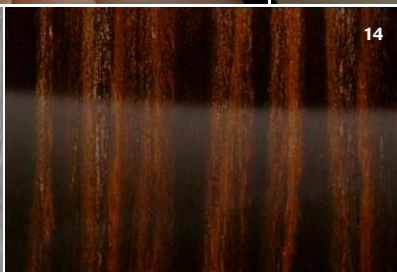
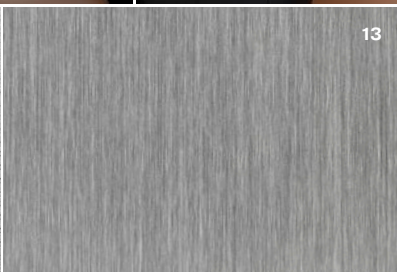



INSPIRED BY THE ART OF DRIVING

If you love to drive, the V60 R-Design is for you. With a unique personality, R-Design captures the thrill of a spirited driving experience characterised by style, responsiveness and control. A wealth of distinguished design details raises the dynamic soul of your Volvo sportswagon and gives it an even sportier, distinct road presence. It's an expression

that catches the eye from every angle and hints at the promise of an amazing drive, every time. And you can rest assured that the V60 R-Design will deliver. Surrounded by meticulously crafted and expressive interior design details, you can feel it right from the moment you take your position in the sculpted R-Design sport seat. Everything – from

the R-Design steering wheel and digital driver display, to the Charcoal headlining – is there to inspire and support your driving. And for even better cornering, the V60 R-Design benefits from a fine-tuned sport chassis.

R-DESIGN

Can be added to Kinetic, Momentum, or Summum equipment levels.

18" Ixion III alloy wheels | 3-spoke perforated leather-clad steering wheel with metal R-Design badge | Adaptive Digital Display with R-Design theme | Dual exhaust with visible tailpipes | Inscription charcoal headlining | R-Design LED daytime running lights | Leather-clad sport gear knob | Nubuck textile/leather upholstery | R-Design interior decor trim | Door mirror caps in silver metallic finish | Sport chassis | Sport floor mats | Sport pedals | Sport seats | Stainless steel tread plates with R-Design logo | Unique R-Design front design | Unique R-Design rear diffuser

R-Design is Volvo in smart designer sports gear – it's all about a performance-inspired look and feel, both inside and out. It's a truly eye-catching expression with sporty exterior design cues, such as its own distinctive grille in Matt Tech Black with high-gloss stripes, front spoiler, Bright Silver matt finish door mirror caps and striking 18-inch alloy wheels. At the back, prominent chrome dual tailpipes and a motorsport style rear diffuser with aero fins add the perfect finishing touch.

On the inside, the sporty theme continues with unique R-Design decor inlays, Charcoal headlining and R-Design sport seats in Nubuck Textile/perforated leather or leather/

perforated leather. Together, these features give the cabin a technical, cockpit-like feel. Contrasting stitching in the seats, the gear shifter gaiter and the steering wheel in perforated leather all reinforce the sporty yet elegant ambience. The deeply sculpted R-Design sport seats will embrace you from your thighs to your shoulders for the comfortable support and in-command feel you expect from a true driver's car. Further adding to your sense of being in control, the R-Design also provides you with a digital driver display with a unique R-Design display mode.

Behind the wheel, you can enjoy the sharp response and feedback from quicker steering

and a finely tuned R-Design sport chassis. Lower and firmer, this chassis features adjusted anti-roll bars and stiffer springs. The unique rear monotube dampers are designed to respond more quickly for improved body control in all conditions. Stiffer bushings together with a front strut brace that stiffen up the body structure give more controlled roll and body movements, resulting in a sporty road-hugging drive without you having to compromise ride comfort.

The V60 R-Design is available with all powertrains including our plug-in hybrids D6 Twin Engine and D5 Twin Engine.



The exterior leaves no doubt about the intention of your V60 R-Design. The exterior colours are carefully selected to match the car's dynamic character – each with its unique expression. For example, the new R-Design exclusive Bursting Blue metallic adds a techy, sporty look that perfectly highlights the body inserts in high-gloss black and silk metal finish. The new stylish Ixion five-spoke R-Design 18-inch or 19-inch wheels give your V60 R-Design a dynamic road presence that puts your sportswagon in a class of its own.



Ixion IV, 8x19"
Matt Black/Diamond Cut



Ixion III, 8x18"
Matt Black/Diamond Cut



614
Ice White



707
Crystal White pearl



477
Electric Silver metallic



713
Power Blue metallic



720
Bursting Blue metallic



714
Osmium Grey metallic



492
Savile Grey metallic



717
Onyx Black metallic



612
Passion Red

*R*DESIGN

Behind the wheel in your V60 R-Design, you can enjoy a dynamic and driver-focused interior made of high-class materials. The sculpted R-Design Sport seats will provide relaxed support through any twists that the road has in store, while the exclusive Nubuck Textile/perforated leather or leather/perforated leather upholstery with contrasting stitching provides a sporty yet sophisticated feel. A sensation further enhanced by the R-Design decor inlays that perfectly complement the Charcoal interior.



UPHOLSTERIES Nubuck Textile/perforated leather **1.** Charcoal/Offblack in Anthracite Black interior with Charcoal headlining, KR60
Leather/perforated leather **2-3.** Offblack in Anthracite Black interior with Charcoal headlining, KT60

INLAYS **4.** R-Design Aluminium decor

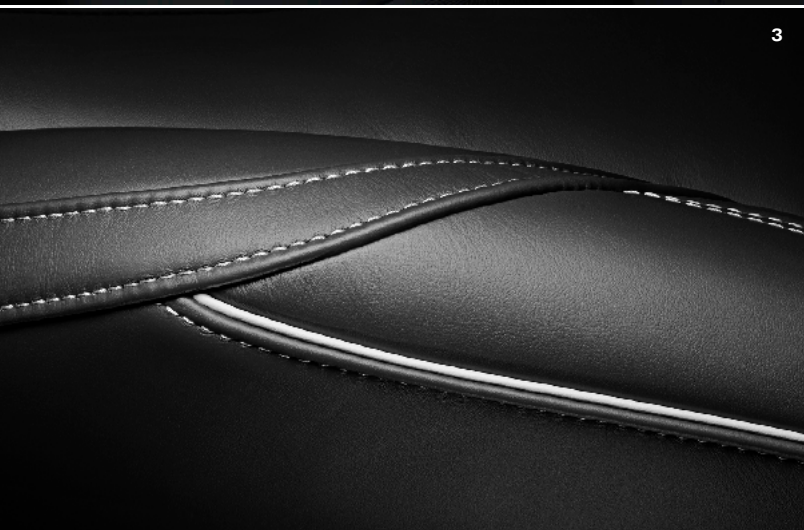



ADVENTURE THAT LIVES UP TO ITS PROMISE

We designed the Volvo V60 Cross Country for adventurous individualists who want to stand out and who need a capable car with a rugged yet refined design that fits in with an active lifestyle. It's a sportswagon crossover that combines dynamism and versatility in a new way to give you an engaging driving experience and the capacity to fulfil your outdoor adventures. Thanks to its raised ground clearance and capable chassis,

the V60 Cross Country delivers what its appearance promises: it has real all-road, all-weather capability that can be further enhanced with all-wheel drive.

Equally at home on all roads – from rough gravel roads to highways – this really is a Volvo for people who don't just talk about adventure, but live it too. For them, all-weather capability and the ability to occasionally leave smooth, well-travelled roads behind are essential.

For that, you need a tough, durable yet stylish partner that doesn't compromise on capability and versatility. And that's really what the V60 Cross Country is all about.

Available in three different equipment levels, you easily create your very own V60 Cross Country. Make your choice, and soon you'll enjoy the adventures that lie ahead.

V60 CROSS COUNTRY

Includes:

16" Pangaea alloy wheels | 3-point safety belts on all 5 seats with belt reminder | 40/20/40 split rear seat | Airbag, driver & passenger side | Audio controls in steering wheel | AUX input | Charcoal decor inlays | City Safety | Corner Traction Control (CTC) | Cruise control | Dual cup holders, front | Electronic Stability Control (ESC) | Electrically operated parking brake | Electronic Climate Control (ECC) with ventilation outlets in B-pillars | Front seat 12V outlet | Headlamp level adjuster | Illuminated vanity mirror, driver side | Illuminated vanity mirror, passenger side | Inflatable Curtains (IC) | ISOFIX, rear | Leather-clad gear knob | Leather-clad steering wheel | LED DRL (Daytime Running Lights) | Load cover | Lock door switch passenger side | Mellbystrand textile upholstery | Outer temperature gauge | Remote control central locking | Sensus infotainment with 5" colour screen in the centre stack and Performance audio system with CD player | Side impact airbags integrated in the front seats | Textile floor mats | Trip computer | Tyre Pressure Monitoring System (TPMS) | Tyre sealant kit | WHIPS™

V60 CROSS COUNTRY MOMENTUM

Includes Cross Country equipment plus the following:

17" Valder alloy wheels | Automatically dimmed frameless inner mirror | Bluetooth® | Bright work around side windows | Tylösand textile/T-Tec upholstery | High Performance audio system | Leather-clad steering wheel with silk metal inlay | Metal luggage threshold | Park assist rear | Rain sensor | Retractable rear-view mirrors with ground lights | Uni décor climate control "manikin"

V60 CROSS COUNTRY SUMMUM

Includes Cross Country Momentum equipment plus the following:

18" Neso alloy wheels | Digital driver display | Leather upholstery | Power driver seat with memory function for seat and side mirrors | Rear armrest with cup holders and storage



Ready for action. This is a Volvo for those individuals who live life as a genuine adventure. And the V60 Cross Country doesn't just look the part, it has got the capability to back up that seriously rugged profile. For example, the Cross Country features 201mm of ground clearance that enhances your ability to take on rough terrain or deep snow and mud.



When adventure takes you to unexplored roads.

The high ground clearance of the V60 Cross Country helps you to stay in control in town, as well as the ability to take on rougher roads. If you choose an all-wheel drive powertrain, you'll have even more capability to carry on when conditions turn difficult. And when you find yourself facing a particularly challenging descent, the Hill Descent Control helps ensure a safe, smooth and "in-control" ride down – all you need to do is steer.

But this is still a true Volvo, with as much ability on all kinds of roads with a suspension that delivers an excellent combination of ride comfort and handling. Enthusiastic drivers

will also appreciate the Corner Traction Control with Torque Vectoring – your V60 Cross Country turns into corners with real sporting precision.

With rugged design elements all around, this car challenges you to take it on an adventure, braving the elements and exploring new terrain. In the front, a black honeycomb grille and lower grille decor elements in black give it our unique Cross Country "face", which is further enhanced by a front skid plate.

The V60 Cross Country is available with five highly efficient powertrains: T5 AWD, T5, D4 AWD, D4 and D3.

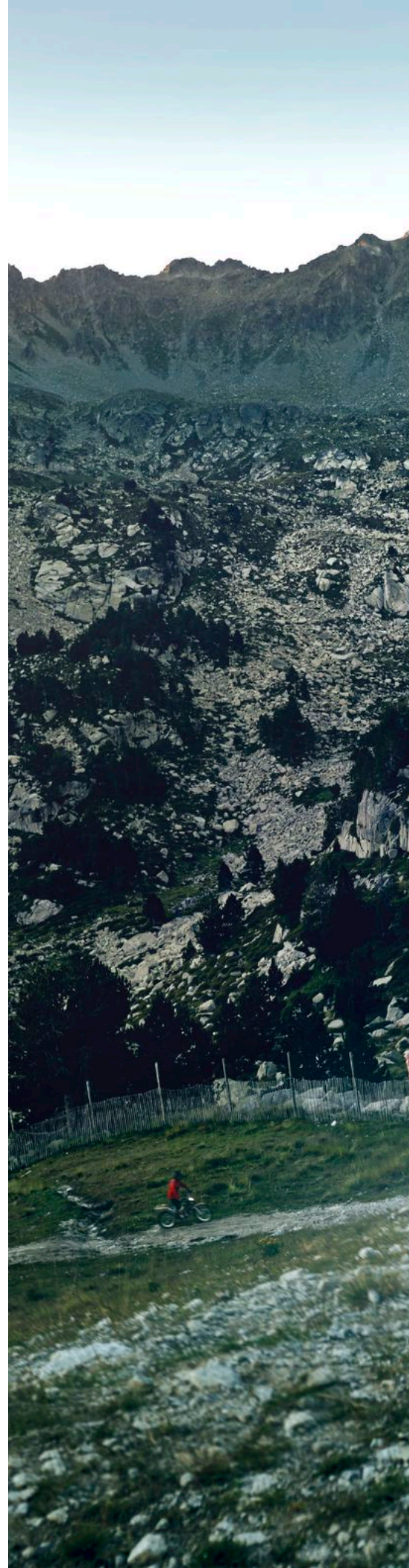





Your perfect companion. The minute you set eyes on the Volvo V60 Cross Country, you know it means business. At the same time, rugged design cues add to the car's muscular stance and leave you in no doubt that this car is ready for any adventure.

This Cross Country sportswagon is a dynamic driver's car, but it also allows you to take everything you need on your weekend away, no matter how remote your destination is. You and your passengers travel first class in ergonomic seats in a well-appointed cabin, while a versatile load compartment makes room for your gear.

So if you're looking for a car that not only stands out of the crowd, but is also a perfect companion for you and your family on all roads, the Volvo V60 Cross Country is for you.

READ MORE AT VOLVOCARS.COM



Looks with a purpose. The V60 Cross Country is a car you spot from a distance. It communicates pride and confidence – and the car's silver roof rails accentuate this stature even further. Take a closer look and you'll find the glossy black detailing on the mirrors and window frames adds another touch of exclusivity.

But the Volvo V60 Cross Country is, above all, a capable, athletic car. The unique 18-inch Neso alloy wheels in diamond-cut design with Matt Tech Black inserts harmonise perfectly with dark exterior design details and add to the purposeful, rugged looks. Black wheel-arch extensions make for a wide, muscular stance and continue seamlessly into the distinctive side scuff plates. A rear skid plate together with integrated chrome tailpipes adds to the powerful impression. And above all: these rugged design elements not only look good, they also protect the body when you are driving in tough conditions beyond the tarmac.

READ MORE AT VOLVOCARS.COM





Your Volvo V60 Cross Country is as personal as the adventures you're going to enjoy in it. Available in three different equipment levels, you'll easily find the V60 Cross Country that's really you.

Generously equipped as standard, the V60 Cross Country provides you with a high level of comfort, safety and performance features. Unique design elements add to the unique Cross Country character: the black grille with a distinctive honeycomb insert, the lower front grille, the front and rear skid plates, the glossy black side window trim and door mirrors, the black wheel arch extensions and matt silver side scuff plates all combine to make a strong statement about style and capacity. The design of the wheels allows for tyre profiles that ensure maximum comfort and handling characteristics.

To further enhance the Cross Country experience, you can choose the V60 Cross Country Momentum. At this equipment level you get larger 17-inch wheels and exterior design details in bright chrome finish for a more luxurious touch and feel. Adding to the contemporary ambience inside the car, the sculpted seats feature our modern, sporty Textile/T-Tec upholstery. Everybody will enjoy the enhanced sound from our High Performance audio system with 8 loudspeakers and USB/AUX connectivity. Bluetooth® streaming allows you to connect your smartphone to your Volvo – so you can enjoy the benefits of music streaming and integrated handsfree phone functionality. And adding the optional larger 7-inch centre display, you'll have full access to Sensus Connect with its wide range of online services and apps. A rain sensor and rear park assist sensors also contribute to a relaxed drive.

For an even more luxurious touch, there's the V60 Cross Country Summum. The 18-inch wheels give a powerful yet elegant road presence that emphasises the get-there-ability of your V60 Cross Country. On the inside, you can enjoy the comfort of seats in smooth leather upholstery with unique colour-coordinated stitching. A power operated driver's seat and a digital driver display with three graphic display modes provide a comfortable driving experience where you are in control. And anyone who shares the ride in the rear seat will enjoy the convenience of a rear armrest with smart cup holders and storage.

1. The integrated chrome tailpipes and rear skid plate lend the tail a rugged yet dynamic look. **2.** The V60 Cross Country is a genuine all-roader with a chassis that delivers a fine combination of ride comfort and handling. **3.** Ground clearance of 201mm and large wheels enhance the all-road capacity. **4.** The side scuff plates harmonise perfectly with the rear and front skid plates and emphasise the high ground clearance. **5.** The glossy black door mirror caps complement the black side window frames for a distinctive, exclusive look. **6.** Urbane wood decor inlays (optional) and leather sport seats with contrasting stitching for your refined experience (Cross Country Summum). **7.** The black honeycomb grille with lower front side mouldings and front skid plate.



Distinctive design elements such as the front and rear skid plates together with the side scuff plates in matt silver finish and the large wheels and black wheel arch extensions create the rugged yet elegant Cross Country look. Inspired by Scandinavian nature, every tone of the exterior colour palette speaks of uniqueness, quality and charisma. And to top the experience, you have a range of specially-designed alloy wheels to choose from – exclusively for your V60 Cross Country.



Bor, 8x19"
Matt Black/Diamond Cut



Portia, 8x19"
Black/Diamond Cut



Neso, 7.5x18"
Matt Tech Black/Diamond Cut



Tucan, 8x18"
Silver Bright



Valder, 7.5x17"
Silver



Pangaea, 7x16"
Silver



614
Ice White



707
Crystal White pearl



711
Bright Silver metallic



477
Electric Silver metallic



721
Mussel Blue metallic



714
Osmium Grey metallic



492
Savile Grey metallic



717
Onyx Black metallic



019
Black Stone



712
Rich Java metallic



700
Twilight Bronze metallic



719
Luminous Sand metallic



612
Passion Red

Inside the V60 Cross Country you'll enjoy an elegantly designed cabin with a superior finish in evidence everywhere you look – from the silk metal finish on our air vents to the fine cloth surfaces on the door pillars and the decor inlays available in aluminium or genuine wood. You can have our Comfort seats in Textile, T-Tec/Textile or leather, while our Sport seats in leather with contrasting stitching give you legendary Volvo comfort while also keeping you firmly in place in those fast corners.



Comfort seat



Sport seat

UPHOLSTERIES **Textile** 1. Charcoal in Anthracite Black interior with Quartz headlining, K001 (Base & Kinetic) **Textile/Neo Tech** 2. Charcoal/Offblack in Anthracite Black interior with Quartz headlining, K601 (Momentum) 3. Charcoal/Offblack in Anthracite Black interior with Charcoal headlining, K661 (Momentum) **Leather Comfort** 4. Offblack in Anthracite Black interior with Quartz headlining, K701 (Summum) 5. Offblack in Anthracite Black interior with Charcoal headlining, K761 (Summum) 6. Soft Beige in Anthracite Black interior with Soft Beige headlining, K70P (Summum) 7. Soft Beige in Sandstone Beige interior with Soft Beige headlining, K71T (Summum) **Leather Sport** 8. Offblack in Anthracite Black interior with Quartz headlining, K30L (Summum) 9. Offblack in Anthracite Black interior with Charcoal headlining, K36L (Summum) 10. Offblack/Blond in Anthracite Black interior with Quartz headlining, K30G (Summum) 11. Offblack/Blond in Anthracite Black interior with Charcoal headlining, K36G (Summum) 12. Offblack/Beechwood Brown in Anthracite Black interior with Quartz headlining, K30N (Summum) 13. Offblack/Beechwood Brown in Anthracite Black interior with Charcoal headlining, K36N (Summum) 14. Soft Beige in Sandstone Beige interior with Soft Beige headlining, K31T (Summum)

INLAYS 15. Charcoal (Base & Kinetic) 16. Milled Aluminium (Momentum, Summum) 17. Brushed Aluminium (Momentum, Summum) 18. Urbane Wood (Summum) 19. Piano Black Wood (Summum) 20. Linear Walnut (Summum)

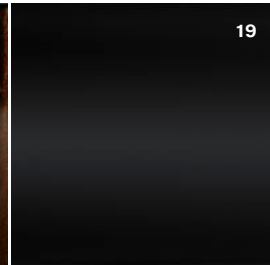
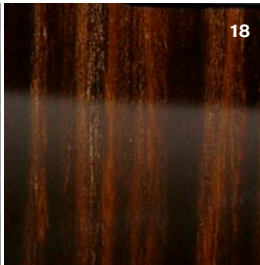
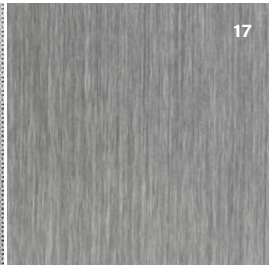
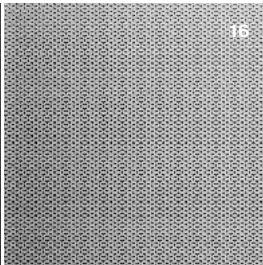



PERFORMANCE FOR REAL LIFE

Experience the thrill of a genuine performance car, fine-tuned for the demands of your everyday route. A car where every component has the purpose of maximising driveability and control, ensuring both an exciting and safe drive in all conditions. A

car that is impressive, agile and extremely responsive and stands out in more ways than one. The V60 Polestar is the result of nearly two decades of racing experience and know-how from exploring the limits of Volvo cars. Together with Polestar's own

engineers and their expertise of building cars with optimum driveability for the race-track, we have developed a performance car for real life. A car that performs on all roads, in all conditions, all year round. In our minds, this is the perfect performance car.

V60 POLESTAR

Includes Summum equipment level plus the following:

20" Polestar bespoke rims | Polestar rear diffuser and front splitter corners | Polestar rear spoiler | Nubuck-clad steering wheel | Nubuck/Leather Sport seats with blue contrast stitching | Polestar pedals and foot rest | Polestar tread plate and gearknob | Polestar chassis with Öhlins Dual Flow Valve shock absorbers and stiffer coil spring | New generation four-cylinder T6 AWD Polestar 367hp engine | 8-speed Geartronic™ transmission | Gear shift paddles | Polestar tuned AWD all-wheel drive | Six-piston Brembo® front callipers and 371mm ventilated brake discs | 2.5" stainless steel exhaust system

Building a racing car with the only aim to be as fast as possible on the track is one thing.

Developing a road car with optimal driveability for all conditions and all roads, is a completely different challenge. The key to any great performance car is a strong and responsive chassis. But this is not the whole story. In order to achieve optimal driveability, everything needs to work together and in tune. The engine, aerodynamics, brakes, transmission, tyres, suspension, all must create, what a race engineer would call, a completely balanced package.

In order to get the car that we wanted, our team of engineers made over 70 modifications and upgrades to the original V60.

In partnership with our long time suspension partner Öhlins, we developed bespoke shock absorbers at a technology level normally found on supercars. Delivering 367hp/470Nm, the Polestar tuned high-performance new generation four-cylinder T6 AWD engine features both a supercharger and turbo to optimise driveability and efficiency at all revs. Further adding to performance, there's a full flow active exhaust system and a re-calibrated engine management system. We also calibrated the 8-speed Geartronic™ transmission and added gearshift paddles to give the driver more control and faster gear shifts. The all-wheel drive system has been tuned to provide increased driving dynamics

with more power to the rear wheels in some situations such as take-off and sharp cornering. Stopping power is optimised through specially-designed 6-piston Brembo® brake callipers and 371mm ventilated brake discs. Add a calibrated aero package and a supportive interior with sculpted Nubuck/leather seats and you will experience a completely balanced car. The Volvo V60 Polestar is a real driver's car made for everyday use and for all roads and conditions. Not just for that perfect sunny Sunday.

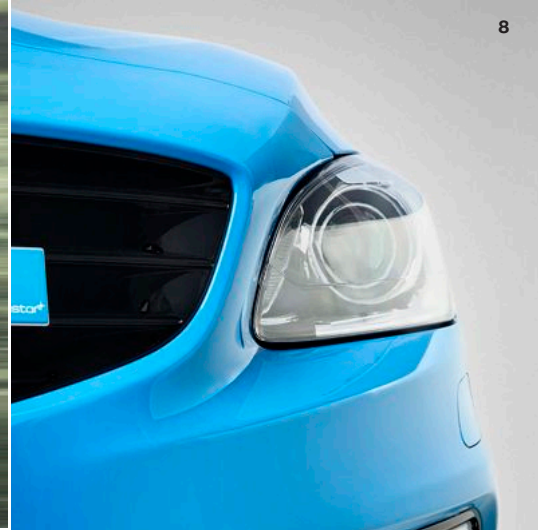
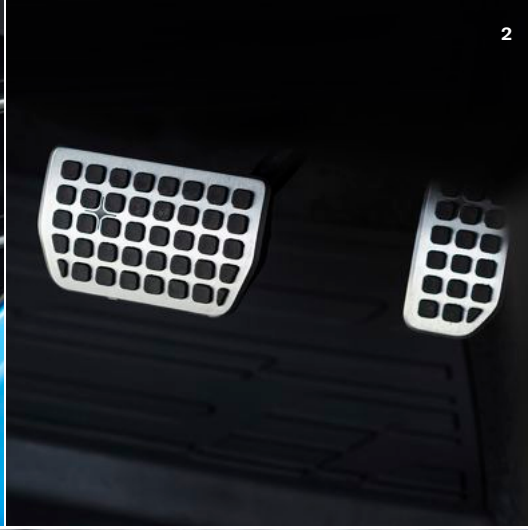

Every component on a performance car needs to work together as one in order to create optimal driveability. The exterior of the car is no exception. For example, the bespoke lightweight Polestar rims, tested and developed in the Volvo wind tunnel, are designed to facilitate optimal airflow to ensure the best possible braking performance in all conditions.



20"

Rims:	Polestar Engineered Rim ER 171-S
Summer tyres:	Michelin Pilot super sport 245/35ZR20 (95Y) XL
Winter tyres:	Michelin Pilot Alpin PA4 245/35R20 (95W) XL Europe Nokian Hakkapelitta 8 245/35R20 (95H) XL Nordic studs



19"

Rims:	Polestar Engineered Rim ER 172-S
Winter tyres:	Michelin Pilot Alpin PA4 235/40R19 (96H) XL Europe Nokian Hakkapelitta 8 235/40R19 (96H) XL Nordic studs Michelin Easy Grip W12



614
Ice White



711
Bright Silver metallic



619
Rebel Blue



717
Onyx Black metallic



Welcome inside. Since the V60 Polestar is a car for those who appreciate active driving, we created an interior that enhances control and puts the driver in command. To start with, the ergonomically sculpted Nubuck/leather seats are carefully designed to keep

you gripped to your seat for increased driver support and control. Blue contrasting details and Carbon Fibre decor inlays combine to enhance the dynamic yet stylish ambience inside your V60 Polestar. Add a Nubuck/leather-clad steering wheel for maximum

grip, tailor-made pedals and foot rest that enhance the feedback from the road and you are in for a great, active driving experience.

UPHOLSTERIES Nubuck Textile/perforated leather 1. Charcoal/Offblack in Anthracite Black interior with Charcoal headlining, KS61.

INLAYS 2. Carbon Fibre.

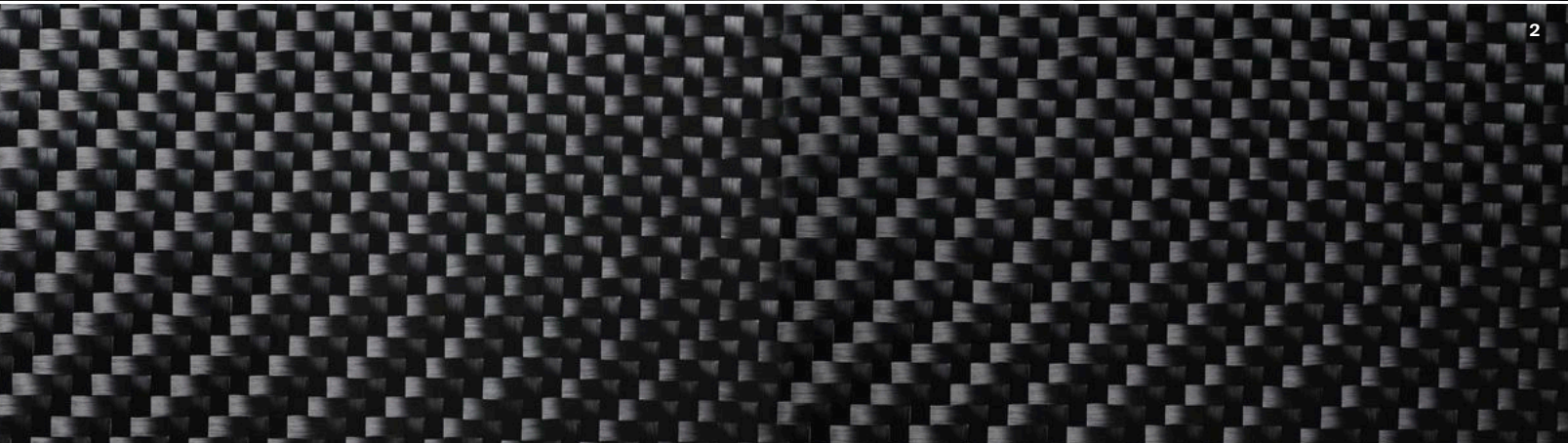



NE

START
STOP
ENGINE



RADIO MEDIA TEL MY CAR
1 2 ABC 3 DEF

OK MENU

“Our park assist camera, front blind view allows you to ‘see around corners’ as you negotiate tight exits.”

NO TWO LIVES ARE THE SAME

Make sure your Volvo matches yours.

A pleasurable part of buying a new Volvo is putting your personal stamp on it. You can do this by choosing accessories that reflect your own taste and that cater to your particular lifestyle.

To take the stress out of driving we have developed technology such as our park assist camera, front blind view. It allows you to see around corners with a 180° field of vision as you negotiate tight exits with restricted visibility. The image is projected onto your 7-inch centre display so you know exactly who, or what, is approaching.

Our park assist camera, rear does the same job when you reverse. It's mounted in the tailgate and dramatically increases your field of vision behind the car. The image is projected

onto your centre display, so you can spot any low obstructions when manoeuvring. There's also a zoom-in view you can use to hitch up a trailer to your towbar.

Since there can only be one driver at a time, the V60 also offers some premium amusement for your rear seat passengers. Our Rear Seat Entertainment system with 8-inch touch screens and integrated DVD players can operate independently. Wireless headphones are standard (you can also plug in your own wired headphones), so one passenger's game doesn't clash with another passenger's movie.

For your children, our new generation Volvo child seats help provide world-class protection and premium comfort. Infants of up to one

year-old (or 13kg) travel safely backwards in our new comfortable rear-facing infant seat. And because we recommend that children should travel facing the rear for as long as possible, our new rear-facing child seat for children up to 6 years (or 9–25kg) allows the child to be seated backwards for many years with generous legroom. When the child has outgrown the rear-facing child seat, our new booster seat with backrest is designed to position the child at the correct height for the safety belt. The child seats' elegant soft wool upholstery matches the interior of your Volvo and provides excellent breathable and moisture-absorbing characteristics for maximum comfort.

To reinforce the dynamic stance of your V60, you can customise it with our Exterior Styling Accessories, which are available in Matt Silver or Matt Iron Stone.

Our eye-catching front skid plate gives your V60 an even more purposeful look, with a metallic colour that's beautifully accentuated as it catches the light. The side scuff plates emphasise the sleek, coupé-like lines, visually connecting it close to the road. The rear skid plates with beautifully sculpted double integrated tailpipes boldly underline the sporty character.

READ MORE AT [VOLVOCARS.COM](https://www.volvocars.com)

The wheels are the jewels of your car. Our gorgeous 18" Modin wheels feature a Diamond Cut five double-spoke design. They too are available in Matt Silver or Matt Iron Stone.







No matter what you like to do in your spare time, there's a pack & load accessory for you. Our exclusive, aerodynamic Space Design roof box looks great, is voluminous and offers minimal wind resistance. It can be opened from both sides and is available in Titan Silver or Black, as well as two sizes: 320 or 430 litres, with a maximum load of 75kg.

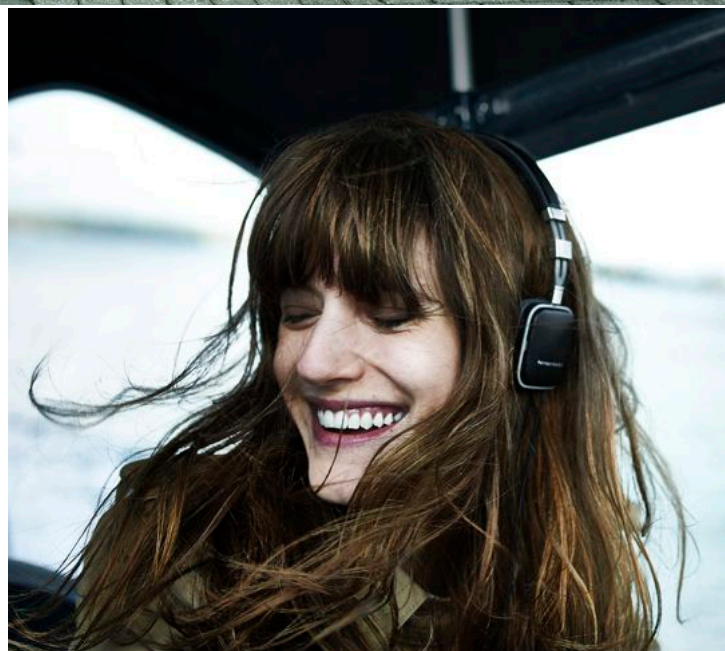

“With the dog gate, you can open the tailgate without your dog leaping out – which makes life so much easier.”



For the load compartment in the rear, there's our steel safety grille, which is an alternative to the standard safety net. This gas-sprung steel grille is colour-coordinated with your interior and helps to protect you and your passengers from unsecured loads when braking sharply. And when you don't need it, it folds conveniently up against the roof.

Our load compartment divider is another great accessory. Used together with the steel

safety grille, this divides the load compartment into two sections – convenient if you want to carry your dog and luggage, or to separate grimy or fragile cargo from other cargo.

Finally, to give your pet a place of its own, you can complement the safety grille and load compartment divider with our dog gate. It allows you to open the tailgate without your dog leaping out – which makes life so much easier.



Artio, 8x19"
Matt Tech Black/Diamond Cut



Modin, 8x18"
Black/Diamond Cut or
Matt Iron Stone/Diamond Cut



Freja, 8x18"
Light Grey/Diamond Cut or
Matt Dark Grey/Diamond Cut



1. The Complete Performance Package includes essential hardware to add performance while subtle exterior details – such as the black door mirror caps and black lower door decor stripes – underline the dynamic appearance of your V60. The Polestar tailgate spoiler will efficiently aid high-speed stability.

Polestar Performance Parts.
Made to Perform.



2. The lightweight Polestar 19-inch alloy wheels with high-performance tyres will help with added steering precision and road grip. **3.** Designed to reduce back-pressure, the stainless steel exhaust system with larger tailpipes gives the engine note a harder edge while also allowing it to breathe more freely for improved performance. A rear diffuser enhances downforce to increase stability at high speeds. **4.** The engraved Polestar tread plate in stainless steel reminds you what you're about to drive every time you open the door. **5.** Sport pedals in aluminium with rubber inserts. **6.** The Polestar gear knob is available for both manual and Geartronic™ transmissions.

It is our passion for driving that led us to design this range of Polestar Performance Parts for your Volvo V60. Developed by the same team responsible for our motorsport success and our dynamic road cars Volvo S60 and V60 Polestar, the new Polestar Performance Parts programme fulfils Volvo Polestar's engineering philosophy by delivering a balanced, energetic driving experience.

The Polestar Performance Parts are designed for the most critical performance areas of your V60 and are available as a Complete Performance Package. This includes every-

thing from improvements to the chassis, wheels and tyres, intake and exhaust as well as aerodynamics and interior details. Any of these components will create a more compelling drive, and are also available in separate packages. With the Chassis Package you'll get Polestar-developed shock absorbers and coil springs, as well as a strut bar, for a more direct and responsive driving experience. The Wheel Package includes the lightweight 19-inch Polestar wheel and high-performance tyres for maximum grip. Then there's the Intake & Exhaust Package, designed for our new generation Drive-E powertrains. It combines a sports air filter with a Polestar air box lid

and a stainless steel exhaust system. This package will deliver the most dynamic engine characteristics when combined with Polestar Performance Optimisation.

All Polestar Performance Parts meet all Volvo safety requirements. They are developed and tested by Volvo Cars and Polestar, ensuring a perfect fit and finish, as well as impeccable road manners, and with no impact on the car's limited factory warranty.

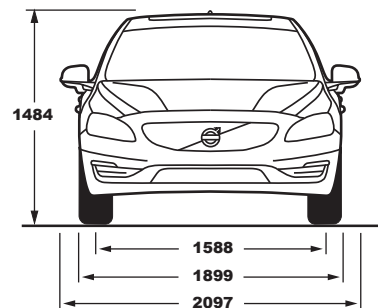
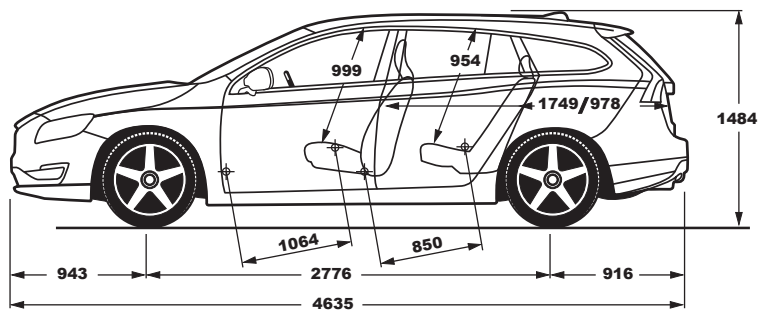

	T6/T6 AWD	T5	T4
Engine type:	2.0L I4 petrol supercharged/turbo	2.0L I4 petrol turbo	2.0L I4 petrol turbo
Transmission:	Eight-speed Geartronic™	Eight-speed Geartronic™	Six-speed manual or six-speed Geartronic™
Fuel consumption, litres/100 km, mixed cycle, man/auto:	-/6.7 -/7.0 (T6 AWD)	-/6.4	5.8/5.8
CO ₂ g/km, man/auto:	-/157 -/163 (T6 AWD)	-/149	135/136
Max. power output, kW (hp) at rpm:	225 (306) 5700	180 (245) 5500	140 (190) 4700
Max. torque, Nm at rpm:	400/2100 - 4800	350/1500 - 4800	300/1300 - 4000
Acceleration, 0 - 100 km/h in sec, man/auto:	-/6.0 -/6.0 (T6 AWD)	-/6.4	7.3/7.3
Top speed, km/h, man/auto:	-/230 -/250 (T6 AWD)	-/230	225/225
Fuel tank, litres:	67.5	67.5	67.5
Environmental classification:	Euro 6	Euro 6	Euro 6
	T3	T3	T2
Engine type:	2.0L I4 petrol turbo	1.5L I4 petrol turbo	1.5L I4 petrol turbo
Transmission:	Six-speed manual	Six-speed Geartronic™	Six-speed Geartronic™
Fuel consumption, litres/100 km, mixed cycle, man/auto:	5.8/-	-/5.9	-/5.9
CO ₂ g/km, man/auto:	135/-	-/138	-/138
Max. power output, kW (hp) at rpm:	112 (152) 5000	112 (152) 5000	90 (122) 5000
Max. torque, Nm at rpm:	250/1300 - 4000	250/1700 - 4000	220/1600 - 3500
Acceleration, 0 - 100 km/h in sec, man/auto:	8.7/-	-/8.7	-/10.3
Top speed, km/h, man/auto:	205/-	-/205	-/190
Fuel tank, litres:	67.5	67.5	67.5
Environmental classification:	Euro 6	Euro 6	Euro 6

Polestar Performance software. The next generation of Polestar Performance delivers a completely new driving experience. Five key areas of the car have been optimised to deliver enhanced driving dynamics and driver control through faster and more precise responses to your commands. All this with maintained certified fuel consumption and Volvo original warranties.

FIND OUT MORE AT [POLESTAR.COM](https://www.polestar.com)

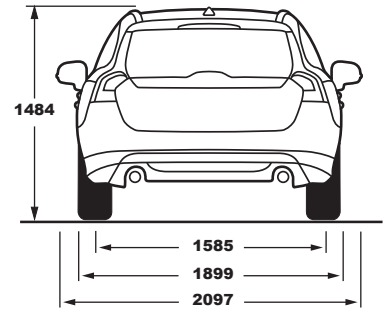
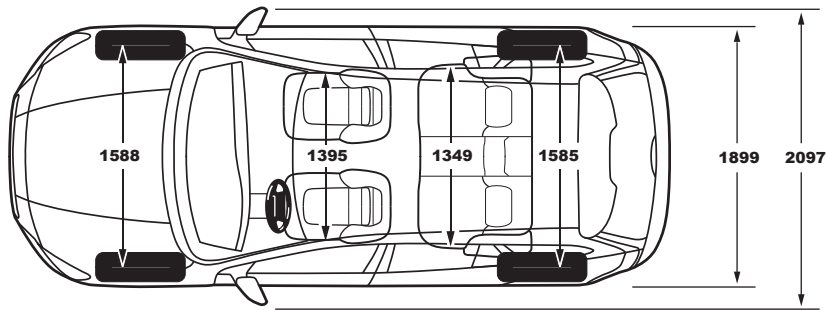

	D6 Twin Engine AWD/ D5 Twin Engine AWD	D5	D4 AWD
Engine type:	2.4L I5 common-rail twin-turbodiesel	2.0L I4 common-rail twin-turbodiesel	2.4L I5 common-rail turbodiesel
Transmission:	Six-speed Geartronic™	Eight-speed Geartronic™	Six-speed Geartronic™
Fuel consumption, litres/100 km, mixed cycle, man/auto:	-/1.8	-/4.8	-/5.5
CO ₂ g/km, man/auto:	-/48	-/125	-/146
Max. power output, kW (hp) at rpm:	Diesel: 162 (220) 4000 (D6) Electric: 50 (68) 2400 (D6) Diesel: 120 (163) 4000 (D5) Electric: 50 (68) 2400 (D5)	165 (225) 4250	140 (190) 4000
Max. torque, Nm at rpm:	Diesel: 440/1500-3000 (D6) Electric: 200/320-1700 (D6) Diesel: 420/1500-2500 (D5) Electric: 200/320-1700 (D5)	470 /1750 - 2500	420/1500 - 3000
Acceleration, 0 - 100 km/h in sec, man/auto:	-/6.0 (D6) -/6.9 (D5)	-/6.5	-/8.9
Top speed, km/h, man/auto:	-/230 (D6) -/210 (D5)	-/230	-/225
Fuel tank, litres:	45	67.5	67.5
Environmental classification:	Euro 6	Euro 6	Euro 6

	D4	D3	D2
Engine type:	2.0L I4 common-rail turbodiesel	2.0L I4 common-rail turbodiesel	2.0L I4 common-rail turbodiesel
Transmission:	Six-speed manual or eight-speed Geartronic™	Six-speed manual or six-speed Geartronic™	Six-speed manual or six-speed Geartronic™
Fuel consumption, litres/100 km, mixed cycle, man/auto:	3.8/4.3	3.9/4.2	3.7/4.2
CO ₂ g/km, man/auto:	101/112	102/109	98/109
Max. power output, kW (hp) at rpm:	140 (190) 4250	110 (150) 3750	88 (120) 3750
Max. torque, Nm at rpm:	400/1750 - 2500	320/1750 - 3000	280 /1500 - 2250
Acceleration, 0 - 100 km/h in sec, man/auto:	7.7/7.7	9.1/9.1	11.5/11.7
Top speed, km/h, man/auto:	225/225	210/210	195/195
Fuel tank, litres:	67.5	67.5	67.5
Environmental classification:	Euro 6	Euro 6	Euro 6

NB. The engine programme may vary from country to country. All technical data may be subject to change. Please talk to your Volvo Car dealer for the latest information.

VOLVO V60 CROSS COUNTRY

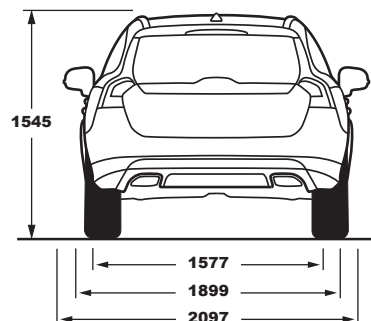
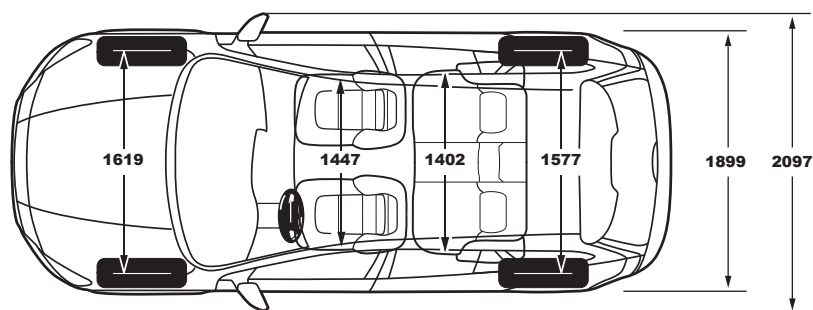
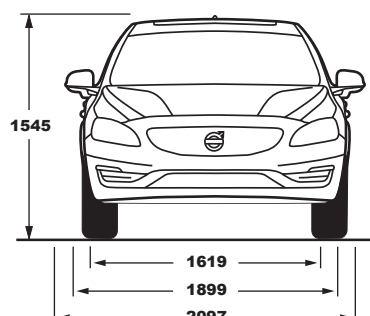
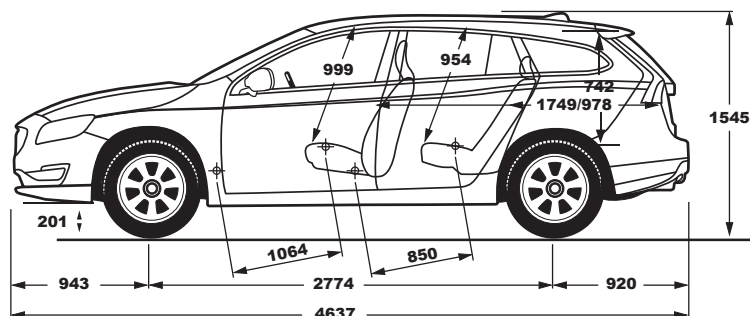

	T5 AWD	T5
Engine type:	2.0L I4 petrol turbo	2.0L I4 petrol turbo
Transmission:	Eight-speed Geartronic™	Eight-speed Geartronic™
Fuel consumption, litres/100 km, mixed cycle, man/auto:	~7.4	~6.6
CO ₂ g/km, man/auto:	~168	~153
Max. power output, kW (hp) at rpm:	180 (245) 5500	180 (245) 5500
Max. torque, Nm at rpm:	350/1500-4800	350/1500-4800
Acceleration, 0-100 km/h in sec, man/auto:	~6.8	~6.6
Top speed, km/h, man/auto:	~210	~210
Fuel tank, litres:	67.5	67.5
Environmental classification:	Euro 6	Euro 6

	D4 AWD	D4	D3
Engine type:	2.4L I5 common-rail turbodiesel	2.0L I4 common-rail turbodiesel	2.0L I4 common-rail turbodiesel
Transmission:	Six-speed Geartronic™	Six-speed manual or eight-speed Geartronic™	Six-speed manual or eight-speed Geartronic™
Fuel consumption, litres/100 km, mixed cycle, man/auto:	~5.7	4.2/4.6	4.2/4.6
CO ₂ g/km, man/auto:	~149	110/120	110/120
Max. power output, kW (hp) at rpm:	140 (190) 4000	140 (190) 4250	110 (150) 4250
Max. torque, Nm at rpm:	440/1500-2750	400/1750-2500	350/1500-2500
Acceleration, 0-100 km/h in sec, man/auto:	~8.9	7.8/7.8	9.1/9.1
Top speed, km/h, man/auto:	~205	210/210	205/205
Fuel tank, litres:	67.5	67.5	67.5
Environmental classification:	Euro 6	Euro 6	Euro 6

NB. The engine programme may vary from country to country. All technical data may be subject to change. Please talk to your Volvo Car dealer for the latest information.

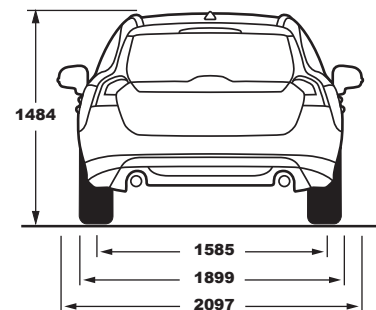
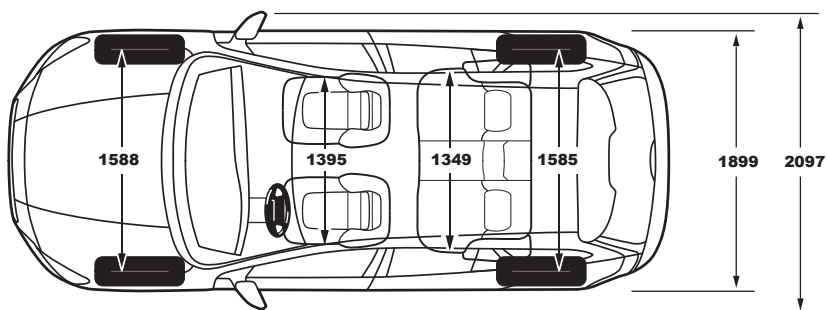
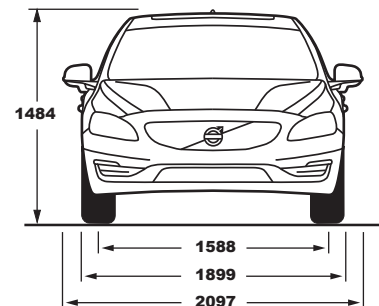
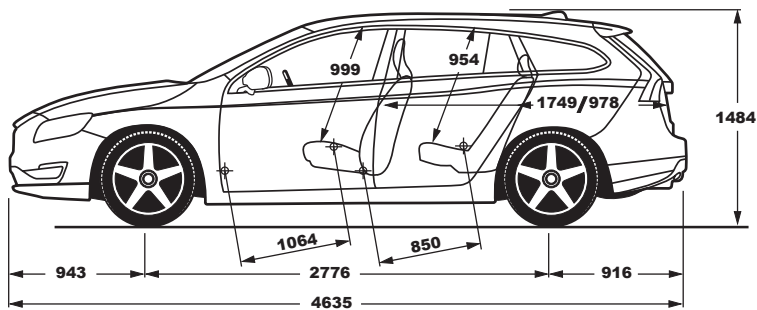

T6 AWD Polestar

Engine type:	2.0L I4 petrol supercharged/turbo
Transmission:	Eight-speed Geartronic™
Fuel consumption, litres/100 km, mixed cycle, auto:	7.8
CO ₂ g/km, auto:	186
Max. power output, kW (hp) at rpm:	270 (367) 6000
Max. torque, Nm at rpm:	470 / 3100 - 5100
Acceleration, 0-100 km/h in sec, auto:	4.8
Top speed, km/h, auto:	250
Fuel tank, litres:	67.5
Environmental classification:	Euro 6
Braking distance (m) from 100 - 0 km/h:	37 m
Turbo system/ Boost pressure (kPa)	260

NB. The engine programme may vary from country to country. All technical data is preliminary and may be subject to change. Please talk to your Volvo Car dealer for the latest information.



The simplest way to own a car.

We love it when you're happy. When things are easier than you expect, or go faster and become better. Because when you buy a Volvo, you buy the simplest way to have a car. Financing, insurance, servicing, changing tyres, cleaning – those aspects of car ownership that you might not find very interesting, are the ones that we love to make easier and better for you. That's why your

Volvo Car dealer will always offer you a whole range of simplifying services and offers all designed around you, giving you the most carefree ownership experience possible.

Still, this is just the beginning. Through our uniquely Swedish approach to innovation, we continuously find new ways to make your life simpler. For instance, the Connected Service Booking function, which lets you book an

appointment just by pushing a button in your car. Or the new way of working in teams – like in a racing pit-stop – that is gradually being introduced in Volvo Car workshops all over the world. We call it Volvo Personal Service and it will make your workshop visits much shorter and more convenient. In the future, servicing your car will be so much simpler.

BUYING & OWNING

- Warranties
- Financing
- Leasing
- Insurance
- Service Contract
- My Volvo website

MAINTENANCE & SERVICES

- Volvo Genuine Service
- Rental cars
- Volvo Professional Car Care
- Tyre services

IF SOMETHING HAPPENS

- Volvo Assistance
- Repairs
- Volvo Glass Services
- Volvo Dent Repair
- Car Climate Services

MY VOLVO

My Volvo is a personalised website that contains everything you need to really get to know – and get the most out of – your car. It gives you:

- A complete overview of your Volvo Car ownership
- Easy access to all facts relating to your car
- Personalised offers and exclusive discounts
- Helpful tips regarding your specific Volvo model
- Instructional films and owner's manuals
- Online Service Booking
- Reminders regarding important stages of your car ownership
- Exclusive articles, films and photographs

CONNECTED SERVICE BOOKING*

If your Volvo has Sensus Connect, it will remind you when it needs servicing and offer to contact your Volvo Car dealer for you. Booking proposals sent from your preferred dealer can easily be managed directly in the car or on your personal My Volvo website. When the time comes to drive to your workshop, your Volvo will remind you and even guide you there. And since your Volvo tells us what it needs, we can make sure it always receives the service it requires when it gets there.

* Available depending on introduction date.
Please Contact your Volvo Car Dealer.

V O L V O